



INTEX™
MILLWORK SOLUTIONS



LIBERTY

EXTRUDED RAIL SYSTEM

INTEX RS60 Liberty Rail System Installation Instructions

Instructional videos are available
online at www.intexmillwork.com



Please Read Before Getting Started

Important Information about Stair Rail with the Liberty Rail System

The Liberty stair rail kit is designed for a maximum overall tread depth of 12" and will meet the building code height requirements in all applications where the stair rise dimensions comply with code. Please note that the height at which the stair rail will meet the newel at the top of the run is determined by the riser height and the set-back distance from the nose of the landing to the face of the newel. If you wish to achieve exact alignment of the sight line between the top of the stair rail and the level rail on the deck, it is recommended to install the stair rail first because it may be necessary to trim the crush block height on the level rails, or use a stair rail transition kit (sold separately) if the overall height exceeds 37 5/8". An optional stair kit with trim-able balusters is available for applications with tread depths exceeding 12". Detailed information concerning sight alignment is on our website at www.intexmillwork.com/libertyinstall or scan this QR code:

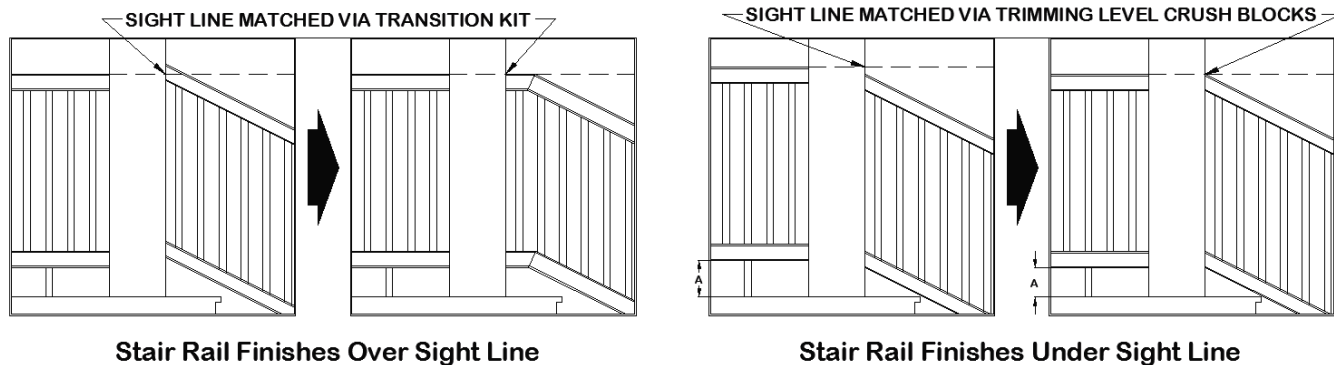

Dark Paint Caution

If you choose to paint your INTEX Millwork Product, INTEX recommends the use of premium grade acrylic paints with solar reflective pigment. Preferably paints designed for use with PVC products. Please contact your local paint dealer for professional assistance. Due to the inherent expansion and contraction characteristics of PVC, INTEX PVC millwork products should only be painted colors with an LVR (light reflective value) greater than 55. Use of darker colors may cause damage due to excessive expansion/contraction, and will void the product warranty.

Cleaning Products for INTEX Millwork Products

Cleaning all INTEX Millwork Products is easy and fast with most major household cleaners. There are many cleaners on the market and the glass cleaners seem to be the best candidate for keeping the finish looking great. The cleaning solution should be applied and immediately wiped dry. As with any cleaning material, the cleaning solution should not be left to stand on the components for an extended period of time.





INTEX recommends the following cleaners:

Windex® 409 Glass and Surface Cleaner®, Spic & Span Cinch®, Fantastik All-Purpose®, Fantastik Orange Action®, Regency® (Glass and Surface), Clorox Clean-Up®, Glass Plus®, Fantastik Oxy Power Multi-Purpose Cleaner®

What to Avoid

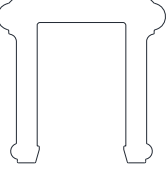
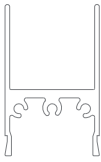
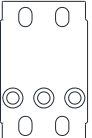
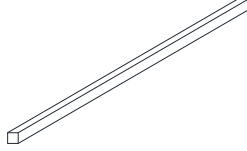
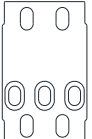
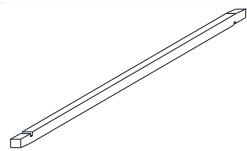
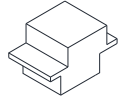
Harsh cleaners with glycol ethers or ethanol type solvents and/or isopropyl alcohol are not recommended. Examples of these harmful cleaners are Goof Off®, Walmart "Great Value All Purpose Cleaner®" (glycol ether), 409 General Purpose® (2- Butoxyethanol) and Greased Lightning® (glycol ether), citrus cleaners, abrasive cleaners, and solvents such as acetone, paint remover and lacquer.

INTEX RS60 Liberty Rail System Installation Instructions

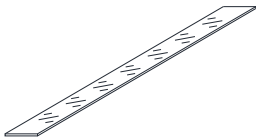
Item		Quantity per Kit		
		6'	8'	10'
Rail Caps 2-3/4" (Graspable) or 3-1/2"		1	1	1
Common Rail (Used at top & bottom of balusters)		2	2	2
Upper & Lower Aluminum Reinforcement		2	2	2
Level Rail Brackets (Included in Level Rail Kits)		4	4	4
Baluster 1-1/4" square 31" or 37" length for Level Rail		14	18	23
Stair Rail Brackets (Included in Stair Rail Kits only)		4	4	4
Baluster 1-1/4" Square 32" Length Machined for Stair Rail Kits Only		14	18	23
Stair Rail Offset Spacer (Included in Stair Rail Kits Only)		2	2	2
Crush Block 1-1/4" Square x 4"		1	2	2
(A) Rail Bracket Screws #8 x 1-1/4" Flat Head Square Drive		16	16	16
(B) Rail Attachment Screws #10 X 3" Slot Hex Washer Head		10	10	10
(C) Crush Block Screws #8 x 2-1/2" Flat Head Square Drive		6	6	6
Glass Baluster 1/4" X 4" Tempered 31" or 37" length for Level Rail (Sold Separately in Packs of 5)		As Required Sold Separately	As Required Sold Separately	As Required Sold Separately

RS60INST 12/1/15

INTEX RS60 Liberty Rail System Installation Instructions

Intex has many how-to videos available on our website to assist you in installing Liberty Rail in various applications. Please go to www.intexmillwork.com and click on the 'Video Help' link at the top of the page. **Please read "Before Getting Started" prior to installing level rail.**

Level Rail Section Application

1. Measure to determine baluster layout, cut rail sections to length.

- a. Ensure newels or columns to which rail will be mounted are plumb and sturdy enough to support rail. If newel/column covers are used, ensure they have blocking at each location where railing will be attached.
- b. Measure span at top and bottom rail locations.
- c. Standard baluster spacing (with the variable spaces at the ends of each rail section), is the only method of spacing available with the Liberty Series Rail. Hold one section of the Top/Bottom Common Rail at the bottom of the newels, and using the baluster locations as a reference, determine the best end baluster spacing by either locating a baluster directly at the center of the rail section, or the mid-point between two balusters as the center of the rail section. Once the best end baluster spacing is decided, mark both ends of the rail at the newels and square cut using a miter box. The Top and Bottom Common Rail must be cut with exactly the same spacing, to ensure that the balusters will be plumb. Cut the Rail Top Cap to the required length.

2. Prepare aluminum reinforcements.

- a. Cut the aluminum rail reinforcements to length, 1/4" shorter than the PVC rails.
- b. Attach a mounting bracket to both ends of each Aluminum Rail Reinforcement, using three *rail bracket screw* (A). Lubricate the threads with soap to avoid binding and use a clutch type drill to avoid stripping screws. Note that the reinforcement for the bottom rail will be installed with the deeper hollow portion facing up, and the reinforcement for the top rail with the deeper hollow portion facing down.
- c. Locate crush block(s) provided to the bottom Aluminum Rail Reinforcement, with spacing no greater than 36" from the end, or between Crush Blocks. Note; in a Glass Baluster application, do not install Crush block at this step. See 4a below.
- d. Drill a 3/16" hole through the bottom Aluminum Rail Reinforcement, and secure each crush block using one *crush block screw* (C).
- e. Drill one additional 3/16" hole at each end of the bottom Aluminum Rail Reinforcement for drainage.

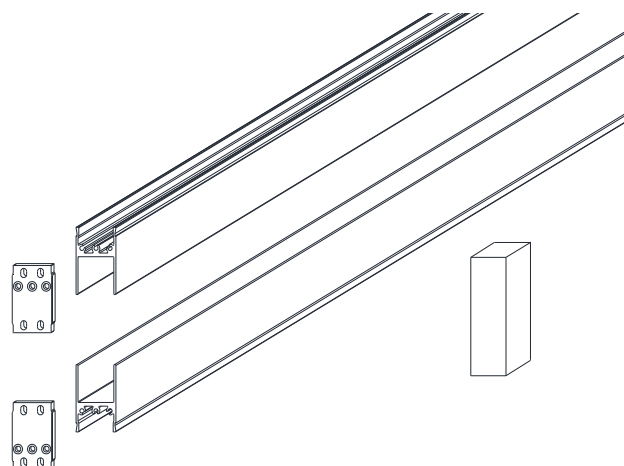

INTEX RS60 Liberty Rail System Installation Instructions

3. Install Rail Section Using 1-1/4" Square Balusters

a. Position the bottom Aluminum Rail Reinforcement, with crush block(s) attached, between the newels or columns, centered on newel or column face. Level and secure each end with two *rail attachment screws* Ⓢ.

b. Place one of the sections of the Top/Bottom Common Rail over the bottom Aluminum Rail Reinforcement.

c. Place balusters into all the baluster slots. Note: if a Baluster will be directly over a Crush Block, trim that Baluster by 1/8" to clear the head of the Crush Block Screw.

d. Starting at one end, align and place the other section of the Top/Bottom Common Rail over top of the balusters. Note that the hollow portion of the Top/Bottom Common Rail will be facing up.

e. Drill three 3/16" holes, one 3" from each end and one at the center of the top Aluminum Rail Reinforcement for drainage.

f. Position the top Aluminum Rail Reinforcement, deeper hollow side facing down, over the ends of the balusters.

g. For level rail sections which exceed 96" length, drill a 3/16" hole through the aluminum reinforcement over the center baluster and the second baluster away to its left and right. In the case of a space-at-center section, drill the hole above the balusters to the left and right of the center. Use caution not to drill into the ends of the balusters, or the screws will strip.

h. Insure that the Aluminum Rail Reinforcement is fully seated on top of all the balusters, and centered on newel or column faces. Pull the Common Rail up against the Aluminum Rail Reinforcement, being careful not to un-seat the Aluminum Reinforcement from the tops of the Balusters, and secure each end with two *rail attachment screws* Ⓢ.

i. Secure the Aluminum Reinforcement to the balusters over which the holes were drilled in section 3g above, with *crush block screws* Ⓢ.

j. Apply a bead of latex caulk at the contact areas where the Rail Top Cap seats on the Top Common Rail. Place the Rail Top Cap on the Common Rail and press firmly down along the length to lock it in place.

4. Install Rail Section Using 1/4" x 4" Tempered Glass Balusters

Note: Glass Baluster application requires the RS60 Liberty series rail sets specifically prepared for the Glass Balusters, along with the appropriate quantities of Tempered Glass balusters (sold separately in packs of 5). Complete steps 1 and 2 as above.

a. Cut the PVC Glass Baluster track to length, and place it into the bottom Aluminum Rail Reinforcement, grooved side up. Locate crush block(s) provided, with spacing no greater than 36" from the end, or between Crush Blocks. Drill a 3/16" hole through the baluster track and the bottom Aluminum

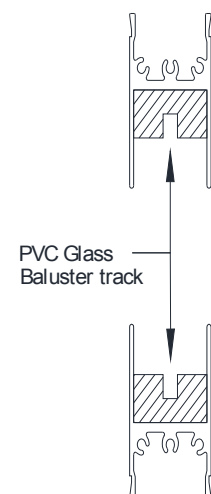

INTEX RS60 Liberty Rail System Installation Instructions

Rail Reinforcement, and secure each crush block using one *crush block screw* ©. Note; offset screw(s) so that they are not in the groove.

b. Position the bottom Aluminum Rail Reinforcement, with crush block(s) attached, between the newels or columns, centered on newel or column face. Level and secure each end with two *rail attachment screws* ©.

c. Place one of the sections of the Top/Bottom Common Rail over the bottom Aluminum Rail Reinforcement.

d. Place Tempered Glass Balusters into all the slots. Note: insure that the ends of the balusters are seated in the groove of the PVC Glass Baluster track.

e. Starting at one end, align and place the other section of the Top/Bottom Common Rail over top of the balusters. Note that the hollow portion of the Top/Bottom Common Rail will be facing up.

f. Drill three 3/16" holes, one 3" from each end and one at the center of the top Aluminum Rail Reinforcement for drainage.

g. Cut the other PVC Glass Baluster track to length and place inside the deeper hollow side of the top Aluminum Rail Reinforcement, so that the grooved side will be facing down when placed over the ends of the glass balusters.

h. Position the top Aluminum Rail Reinforcement, with PVC Glass Baluster track in place, over the ends of the balusters.

i. Insure that the upper and lower ends of the glass balusters are seated in the grooves of the baluster tracks, and that the Aluminum Rail Reinforcement is fully seated on top of all the balusters, and centered on newel or column faces. Pull the Common Rail up against the Aluminum Rail Reinforcement, being careful not to un-seat the Aluminum Reinforcement from the tops of the Balusters, and secure each end with two *rail attachment screws* ©

j. Apply a bead of latex caulk at the contact areas where the Rail Top Cap seats on the Top Common Rail. Place the Rail Top Cap on the Common Rail and press firmly down along the length to lock it in place.

Stair or Rake Rail Application

Note: Please read "Before Getting Started" prior to installing stair rail

1. Determine baluster layout, cut rail at required length and angle

a. Ensure newels or columns to which rail will be mounted are plumb and sturdy enough to support rail. If newel/column covers are used, ensure they have blocking at each location where railing will be attached.

b. Standard baluster spacing (with the variable spaces at the ends of each rail section), is the only method of spacing available with the Liberty Series Rail. Determine best end spacing by placing the bottom Common Rail on the stairs, between the newels and either locating a Baluster directly at the center of the rail section, or the mid-point between two Balusters as the center of the rail section. Once baluster spacing is determined, mark ends of the bottom Common Rail with length and angles.

INTEX RS60 Liberty Rail System Installation Instructions

c. Using the two Stair Rail Offset Spacers supplied with Stair Rail kit, place the Top and Bottom Common Rail together and make a single cut across each end of the Common Rails, at the locations/angles determined above. Both Common Rails will be the same length, but the Stair Rail Offset Spacers will offset the baluster spacing by 3/16" to keep

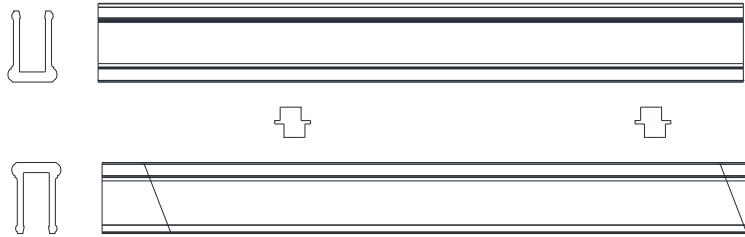

the Balusters plumb once installed at the stair angle. Note: do not cut the Rail Top Cap until section is assembled and secured at all 4 mounting points.

2. Prepare aluminum reinforcements.

a. Cut the Aluminum Rail Reinforcements to the same angles as the Top and Bottom Common Rail, but 1/4" shorter in length. Note that the top reinforcement is oriented with the deeper hollow portion facing down, and the bottom reinforcement is oriented with the deeper hollow portion facing up. Secure a Stair Rail Bracket to each end of both reinforcements, using three *rail bracket screws* (A). Lubricate the threads with soap to avoid binding and use a clutch type drill to avoid stripping screws.

b. Cut one end of Crush Block to angle of rail and locate to the bottom aluminum rail reinforcement, with spacing no greater than 32" from the end, or between Crush Blocks. Ensure that the Crush Block(s) will be located on a stair tread.

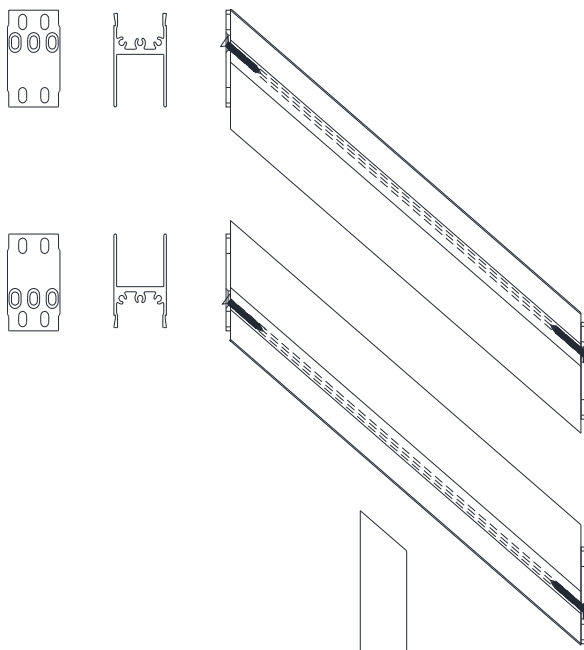

c. Drill a 3/16" hole through the bottom Aluminum Rail Reinforcement, and secure each crush block using one *crush block screw* (C).

d. Position bottom Aluminum Rail Reinforcement, with crush block(s) attached, between the newels or columns, centered on newel or column face, and insure proper placement in relation to the ends of the treads. Secure each end with two rail attachment screws (B). Note: due to the angles, the heads of the rail bracket screws (A) used to attach the brackets to the reinforcements will protrude from the face of the brackets. Use care to avoid damaging the newel posts when positioning the reinforcements.

INTEX RS60 Liberty Rail System Installation Instructions

3. Assemble rail/baluster section.

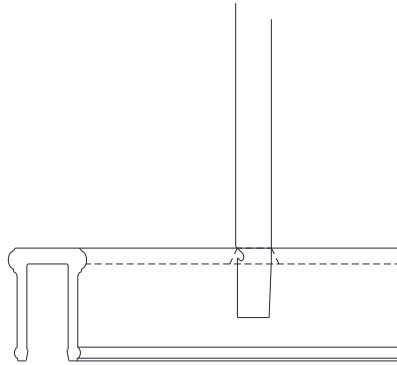

a. Insert balusters into the bottom Common Rail, with the lower notch oriented so that it is on the up-hill side of the baluster when the rail is in place. Each Baluster should 'click' into place.

b. Starting at one end, align and place the other section of the Top/Bottom Common Rail over top of the balusters. Note that the hollow portion of the Top/Bottom Common Rail will be facing up, and insure that the rake angles at the ends

correspond to those on the bottom Common rail. Insure all Balusters are properly seated so that the notch is 'clicked' into the Top/Bottom Common Rails. If a baluster pushed through the rail too far, or not far enough, it may cause the machined slot to be deformed. The Assembly should rack easily.

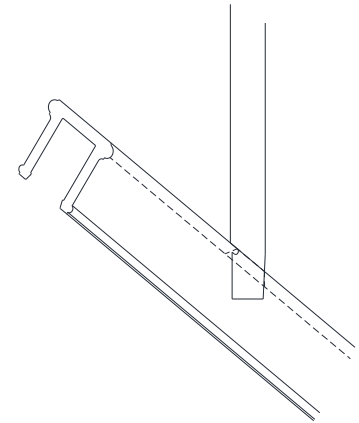

4. Install rail

a. Rack and position the rail/baluster assembly between newels or columns and seat fully down on bottom aluminum rail reinforcement.

b. Seat upper Aluminum Rail Reinforcement into the top Common Rail.

c. Ensure rail is centered on face of newel or column and secure each end with two *rail attachment screws* ®.

g. Measure and cut the Top Cap to required angle and length. Apply a bead of latex caulk at the contact areas where the Rail Top Cap seats on the Top Common Rail and Seat the Rail Cap fully onto the Top Common Rail.

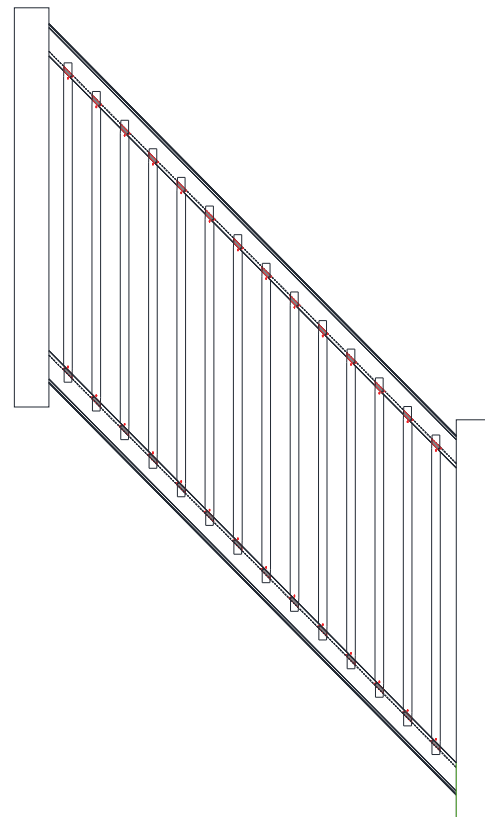

RS60INST 12/1/15